



UNIFIED INDUSTRIES, INC.

Howell, Michigan



Solutions Brochure



Unified Industries, Inc. Setting the Standards

Unified Industries has provided overhead material handling systems to the manufacturing markets since 1953. Over the years, Unified Industries has evolved from a small fixture and gauging shop to a full service material handling systems provider. Innovative products provide cost effective solutions for any material handling need and pioneering advanced technologies keep our products ahead of the competition. Our high quality and customer service have

continually made us the standard throughout the material handling industry.

Our capabilities and products continue to expand our Ergonomic Solutions including Pneumatic Balancers, Articulating Arms, Torque Reaction Tubes and Custom Ergonomic Assists. Unified Industries can take your project from concept to solution and onto your plant floor.



Products

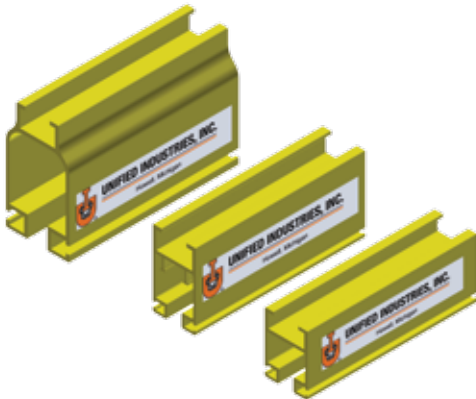

ETA – 4, 5 & 8 Rail Systems

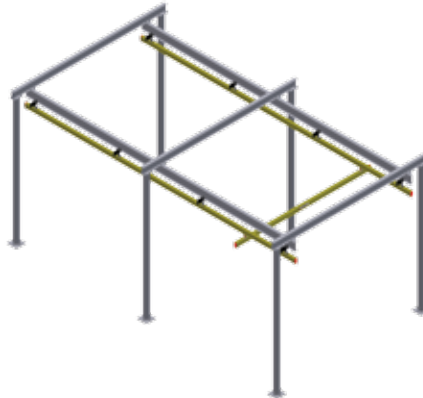

Free Standing Structures



Ergonomic Systems



Torque Reaction Tubes



Air Balancer



Tractor Drives

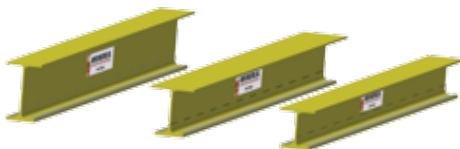

4", 5" & 6" Patented Track System

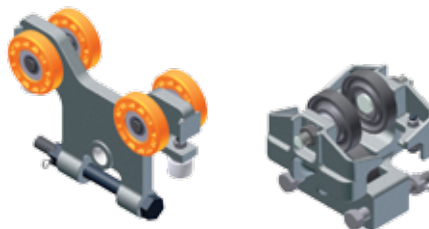

Trolleys

Designed Differently

- ETA rail systems are ergonomically designed to solve your material handling challenges
- Rail lengths range up to 42' without requiring a splice
- Strong backing of the ETA rail offers added capacities for tough applications
- Articulating end-trucks add versatility and ease of motion
- ETA systems offer substantial weight reduction over steel rail
- ETA systems provide smooth quiet operation
- Straight track, standard and compound curves.
- ETA systems can be adapted to S-Beam or patented track runways
- Jib cranes
- Cranes are pre-assembled in the factory
- Unified Industries manufactures a 4", 5", and 6" patented track to complement our Trambeam line
- Air balancers and controls
- Pneumatic and electric tractor drives
- Complete line of air, electric chain and wire rope hoists
- Spring balancers and retractors
- Articulating arms, torque reaction tubes and custom ergonomic assists
- Complete line of patented track & S-Beam trolleys up to 4000 lbs capacity

The Unified Industries Commitment

1. Customer Focused Organization - “Responsibility, Authority, Accountability”
2. Cost of Non-Conformance - “Cost of NC Impacts Customer & Unified Industries”
3. Drive Customer Involvement - “Commitment to everyone's success”
4. Safety Focus - “Safe products / Safe workplace”
5. Sales, Engineering, & Manufacturing - “Know the Product and the Project”
6. Qualified Experienced Suppliers - “Develop Unified / Supplier Relationship”
7. Modular Design & Build - “Customer receives material ready to install”
8. Project Schedules - “Be ahead of schedule”
9. Management By Walking Around - “Be accessible to all, handle the details”
10. Special focus on Complex Areas - “Check and Re-Check”



Mission Statement

The Unified Industries mission is to provide our Customers with people, business practices, and material handling equipment of the **Highest Integrity.**

ETA-8 Double Girder Front Sub-Assembly with Ergonomic Lift Assist

Unified Industries System Installations



Unified Patented Track System



ETA-8 Double Girder Crane System with Ergonomic Lift Assist



Maintenance Repair Patent



ETA-8 Body Shop Automation Crane and Runway System



**Front End Sub-Assembly
ETA-8 Curve Monorail**

Unified Industries System Installations



Trim Assembly Carpet Install

This application combines ETA-4 and ETA-8 systems to reduce the overall weight and allows the operator ease of motion on the articulating arm. We include design, manufacturing, run-off and installation in your plant.



Axle Build Area

When excessive spans are required, count on Unified Industries ETA-8 enclosed aluminum rail and bridge systems. With the addition of a third runway rail in the center of the bridge, increased spans are achieved without compromising the smooth and easy operation of the system.



Final Assembly Electrical Check

ETA-4 Enclosed Aluminum Rail is ideal for use as tool rail to hold testing consoles, miscellaneous air and electrical fastening tools as well as parts bins. When long continuous runs are required, maintenance/inspection gates can be added to aid in the removal or addition of trolleys and equipment.



Front End Sub-Assembly

When retractable bridge telescopes are required, Unified Industries is your supplier of choice. Unified Industries manufactures a wide variety of telescoping and retractable bridge crane extensions in varying capacities and lengths. Let our sales staff recommend and design a system to meet “YOUR” needs.

Ergonomic Solutions

Whether the solution requires a custom developed product or a less complicated lean tool solution, Unified Industries has a full line of products to solve your material handing needs. Solutions are built within a partnership between our customer and Unified Industries to meet and exceed all expectations.

Concept

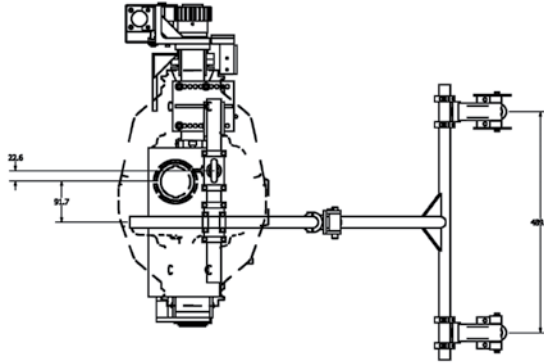

Design

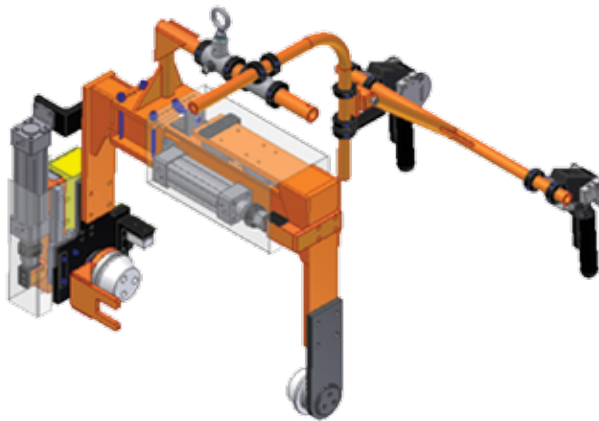

Build



Concept To Solution

Internal Meeting w/Estimating

Kickoff Meeting w/Customer

Concept Review

Design Buyoff

Build

Internal Buyoff

Customer Buyoff

Ship/Complete



Our Facility



**Visit our website at www.unified-ind.com
for our downloadable catalog, brochure,
contact list and distribution partners.**



UNIFIED INDUSTRIES, INC.

1033 Sutton Street • Howell, MI 48843
517.546.3220 • Fax 517.546.1273
www.unified-ind.com

